

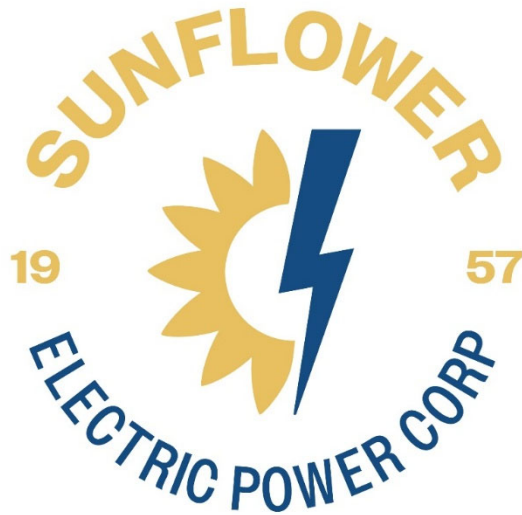

**Interconnection Facilities Study  
for GEN-2023-107 Network Upgrades and TOIF upgrades at  
the Setab 345 kV Substation**



**April 10, 2026**

## **TABLE OF CONTENTS**

Study Overview: .....	2
Interconnection Facilities and Non-Shared Network Upgrades: .....	2
Interconnection Costs:.....	4
Project Timeline: .....	4

## **STUDY OVERVIEW:**

The Southwest Power Pool has requested a Facility Study for Interconnection Facilities and Network Upgrades from Sunflower Electric Power Corporation (Sunflower) at the Setab 345 kV Substation for request GEN-2023-107. The GEN-2023-107 request consists of a total of 300 MW of wind generation interconnecting at the Setab 345 kV Substation.

The Non-Shared Network Upgrades (NU) identified to accept a new generator lead includes terminal equipment to accept a new line at the existing Setab 345 kV Substation. The cost for these Network Upgrades is estimated at \$11,750,592.

The Transmission Owner Interconnection Facility (TOIF) addition identified is a new 345 kV generator lead connection at the existing Setab 345 kV Substation. The cost for adding the new 345 kV generator lead is estimated at \$5,250,139.

The purpose of this study is to provide estimated costs of facilities required for interconnection of the proposed generation to Sunflower's transmission system and to identify scope and estimated costs for network upgrades required on Sunflower's transmission system to allow the generation to run at the full requested capacity.

Additional network upgrades required for facilities of other transmission owners are not included in this study and will be identified by SPP.

## **INTERCONNECTION FACILITIES AND NON-SHARED NETWORK UPGRADES:**

Non-shared Network Upgrades (NU) additions required by Sunflower consist of the required 345 kV upgrades with circuit breakers, CCVTs, disconnect switches, structures, foundations, conductors, insulators, and all other associated work and materials.

Transmission Owner Interconnection Facility (TOIF) additions required by Sunflower consist of revenue metering CTs and PTs, disconnect switch, protective relays, and terminal equipment needed to interconnect the customer's generator lead line to Sunflower's Setab 345 kV Substation.

This 345 kV addition at Setab 345 kV Substation shall be constructed and maintained by Sunflower. It is assumed that obtaining all necessary right-of-way for the line into the Sunflower 345 kV substation facilities will be performed by the interconnection customer. The addition of the generator 345 kV lead line from the customer substation into the existing Sunflower Setab Substation and the step-up transformer that connects to the customer's collector substation is not included and is the responsibility of the interconnection customer.

The proposed arrangement for interconnection of GEN-2023-107 is shown in Figure 1.

# Interconnection Facilities Study – Setab 345 kV Network Upgrades and TOIF

## Figure 1: One-line Diagram Facilities for GEN-2023-107

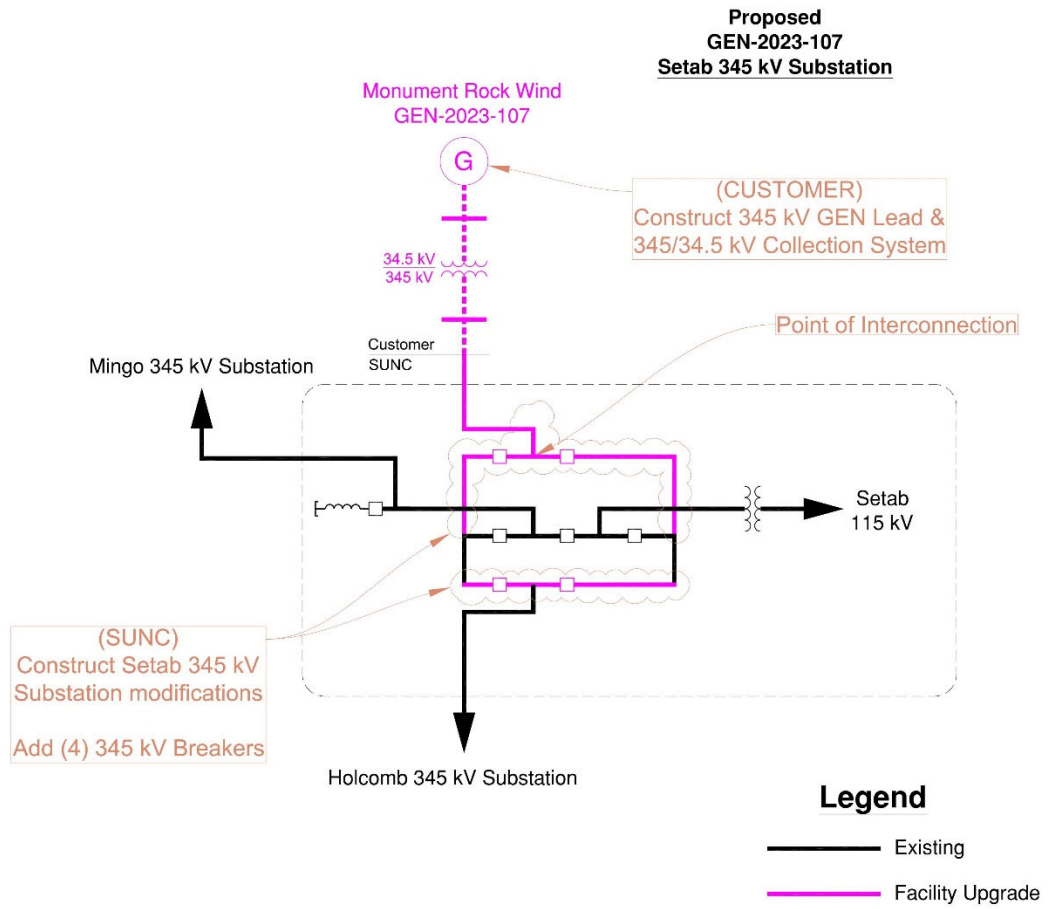

## INTERCONNECTION COSTS:

Summary of interconnection costs for both Interconnection Facilities and Sunflower identified Network Upgrades can be found in the following table.

Upgrade Type	UID	Upgrade Name/Description	DISIS Cost Estimate	DISIS Lead Time
Interconnection	158675	<b>Setab 345 kV GEN-2023-107 Interconnection (Non-Shared NU) (SEPC)</b> Construct the required 345 kV upgrades with circuit breakers, CCVTs, disconnect switches, structures, foundations, conductors, insulators, and all other associated work and materials.	\$11,750,592	42
Interconnection	158849	<b>Setab 345 kV GEN-2023-107 Interconnection (TOIF) (SEPC)</b> Construct one (1) line terminal addition in the new 345 kV substation with revenue metering CTs and PTs, disconnect switch, protective relays, and terminal equipment needed to interconnect the customer’s generator lead line.	\$5,250,139	42
<b>Total Interconnection Cost:</b>			<b>\$17,000,731</b>	

## PROJECT TIMELINE:

Specific construction schedule and milestones will be determined during the Generator Interconnection Agreement negotiations. Sunflower is estimating an engineering and construction schedule for this project as approximately 42 months. Other factors associated with clearances, equipment procurement delays and work schedules could cause additional delays. This is applicable after all required agreements are signed and internal approvals are granted.

**NPPD  
DISIS-2023-001  
FACILITY STUDY**

**GEN-2023-222/223 (Beatrice Power Station)  
GEN-2023-224/225 (Princeton Road Station)**

**FEBRUARY 2026**

**PREPARED FOR:  
SOUTHWEST POWER POOL**

**PREPARED BY:  
NEBRASKA PUBLIC POWER DISTRICT  
ENERGY DELIVERY  
TRANSMISSION ASSET PLANNING  
ENGINEERING & ASSET MANAGEMENT**



**Nebraska Public Power District**

*"Always there when you need us"*



## **Introduction**

The *NPPD DISIS-2023-001 Facility Study* was performed to document the interconnection facilities and network upgrades identified by SPP in Phase 2 Re-Study #1 of the SPP DISIS-2023-001 Study for the following requests:

GEN-2023-222 (Beatrice Power Station)  
GEN-2023-223 (Beatrice Power Station)  
GEN-2023-224 (Princeton Road Station)  
GEN-2023-225 (Princeton Road Station)

NPPD also reviewed the proposed interconnection facilities and network upgrades and associated generation interconnection request impacts on the Short Circuit capability of the NPPD system. The NPPD Facility Study includes detailed cost estimates and estimated project schedules for the upgrades identified in the SPP and NPPD studies.

The initial list of Interconnection / Network Upgrades from DISIS-2023-001 Phase 2 Re-Study #1 for the GEN-2023-222, GEN-2023-223, GEN-2023-224, and GEN-2023-225 GI requests is below:

- Beatrice Power Station 345 kV Substation
- Princeton Road Station 345/115 kV Substation
  - Connected to NPPD Olive Creek and LES 345/115 kV transmission lines at site location
- Daykin 345 kV substation
- Beatrice Power Station – Daykin 345 kV line
- Beatrice Power Station – Olive Creek 345 kV line
- Second Red Willow 345 kV Transformer
- Upgrade Lowell – Minden 115 kV line

## **Short Circuit Study – Initial**

NPPD's Engineering group has reviewed the short circuit impacts of the initial SPP DISIS-2023-001 Generation Interconnection projects and associated network upgrades interconnected to the NPPD transmission system. The result of this study is documented in Appendix 1.

The short circuit study identified 39 breakers on the NPPD system that were overdutied with the initial interconnection plan for GEN-2023-222, GEN-2023-223, GEN-2023-224, and GEN-2023-225. Many of these breakers (37 total) are 63kA units that were recently installed at the Sheldon / Olive Creek 115 kV substations associated with the Monolith Materials project. 63kA is the maximum standard 115 kV breaker for NPPD. Replacement of these brand-new breakers is not a feasible solution, and alternatives must be considered.

NPPD evaluated several options to determine the optimal solution to mitigate the short circuit impacts for the local area. At this time, the following system topology changes are considered the optimal transmission plan (transmission option 1e) for the local area to address the short circuit issues identified in the DISIS-2023-001 Short Circuit Study – Phase 1.

### Transmission Option 1e

- Relocate Moore T1 transformer to Princeton Road Station and install new 115 kV line from Princeton Road to Sheldon using the existing Moore T1 115 kV tie line terminal at Sheldon Station.
- Relocate Olive Creek T2 transformer to Beatrice Power Station.
- Single 345 kV transmission line from Princeton Road Station to Olive Creek.
- Install additional grounding on generation interconnection request step-up transformers associated with all IBR's at Olive Creek 115 kV substation (GEN-2013-002, GEN-2013-019, GEN-2019-041, GEN-2021-027)

## **Loadflow Study**

In order to ensure the proposed short circuit solutions listed above can be implemented reliably, NPPD performed a loadflow study evaluating the transmission configuration alternatives. These transmission options were evaluated using the out-year LVER study models associated with DISIS-2023-001 Phase 2 Re-study #1.

In addition, NPPD evaluated several different generation dispatch scenarios for units in the local area. The SPP LVER models do not properly account for the output of all prior queued network resources (NITS) in the local area (Sheldon Station, Hallam, Beatrice Power Station). It is important to ensure these resources are evaluated at full output levels to ensure deliverability to NPPD network load and reliability is not compromised and to meet NERC FAC-001 requirements documented in NPPD's Facility Connection Requirements Document. NPPD also reviewed alternative load scenarios for the load customer at Olive Creek (Monolith Materials) as it has been slow to develop and may not reach the forecasted levels modeled in the SPP LVER cases utilized for DISIS-2023-001.

NPPD utilized PSS/E Activity ACCC to scan for local area transmission issues for system intact and single contingency event scenarios in the NPPD modeling area. The transmission options and dispatch scenarios evaluated in this loadflow study are listed in Tabel 1 below. A total of 60 study cases were developed to evaluate the transmission options and dispatch scenarios selected for this analysis.

**Table 1. Loadflow Study Parameters**

SPP GI Study Models	
27SP	SPP LVER model: DIS231-TC00ALL-27SP0.sav, 2027 Summer Peak
27WP	SPP LVER model: DIS231-TC00ALL-27WP0.sav, 2027 Winter Peak

Transmission Options	
1a	SPP re-study1 transmission with additions of LES lines interconnected at Princeton Road
1b	remove 1 Olive Creek-Princeton Road 345 kV
1c	remove 1 Olive Creek-Princeton Road 345 kV and remove 1 Olive Creek 345/115 kV
1d	remove 1 Olive Creek-Princeton Road 345 kV and remove Moore 345/115 kV and add Sheldon-PRS 115 kV CKT 2
1e	remove 1 Olive Creek-Princeton Road 345 kV and remove Moore 345/115 kV and add Sheldon-PRS 115 kV CKT 2 and remove Olive Creek 345/115 kV T2

Dispatch Scenarios	
S00	Standard SPP LVER Dispatch
S2A	LVER + Sheldon, Hallam, BPS dispatched to PMAX
S2B	LVER + Sheldon, Hallam, BPS dispatched to PMAX + Monolith load reduction to 30 MW (from 255 MW)
S2C	LVER + Monolith load reduction to 30 MW (from 255 MW)
S2D	all generation offline
S2E	all generation offline + Monolith load reduction to 30 MW (from 255 MW)

**Table 2. 2027 Summer Peak Loadflow Study Result Summary**

Case	Dispatch Scenario	Transmission Option	Thermal Issue
27SP	S00	1a	99.8% loading on Firth-Olive Creek 115 kV FLO S1263 Wbrock 161/69 kV Trf
27SP	S00	1b	99.8% loading on Firth-Olive Creek 115 kV FLO S1263 Wbrock 161/69 kV Trf
27SP	S00	1c	None
27SP	S00	1d	99.0% loading on Firth-Olive Creek 115 kV FLO S1263 Wbrock 161/69 kV Trf
27SP	S00	1e	None
27SP	S2A	1a	109.6% loading on Beatrice-Harbine 115 kV FLO McCool 345/115 kV Trf
27SP	S2A	1a	105.5% loading on Firth-Olive Creek 115 kV FLO S1263 Wbrock 161/69 kV Trf
27SP	S2A	1b	109.6% loading on Beatrice-Harbine 115 kV FLO McCool 345/115 kV Trf
27SP	S2A	1b	105.5% loading on Firth-Olive Creek 115 kV FLO S1263 Wbrock 161/69 kV Trf
27SP	S2A	1c	109.4% loading on Beatrice-Harbine 115 kV FLO McCool 345/115 kV Trf
27SP	S2A	1c	104.5% loading on Firth-Olive Creek 115 kV FLO S1263 Wbrock 161/69 kV Trf
27SP	S2A	1d	109.5% loading on Beatrice-Harbine 115 kV FLO McCool 345/115 kV Trf
27SP	S2A	1d	105.2% loading on Firth-Olive Creek 115 kV FLO S1263 Wbrock 161/69 kV Trf
27SP	S2A	1e	109.3% loading on Beatrice-Harbine 115 kV FLO McCool 345/115 kV Trf
27SP	S2A	1e	103.9% loading on Firth-Olive Creek 115 kV FLO S1263 Wbrock 161/69 kV Trf
27SP	S2B	1a	114.7% loading on Firth-Olive Creek 115 kV FLO S1263 Wbrock 161/69 kV Trf
27SP	S2B	1a	<b>101.6% loading on Beatrice-Harbine 115 kV SYSTEM INTACT</b>
27SP	S2B	1a	115.4% loading on Beatrice-Harbine 115 kV FLO Daykin - Elm Creek 345 kV
27SP	S2B	1a	111.5% loading on Beatrice-BPS 115 kV 2 FLO Beatrice-BPS 115 kV 1
27SP	S2B	1a	111.0% loading on Beatrice-BPS 115 kV 1 FLO Beatrice-BPS 115 kV 2
27SP	S2B	1b	114.7% loading on Firth-Olive Creek 115 kV FLO S1263 Wbrock 161/69 kV Trf
27SP	S2B	1b	<b>101.6% loading on Beatrice-Harbine 115 kV SYSTEM INTACT</b>
27SP	S2B	1b	115.4% loading on Beatrice-Harbine 115 kV FLO Daykin - Elm Creek 345 kV
27SP	S2B	1b	111.5% loading on Beatrice-BPS 115 kV 2 FLO Beatrice-BPS 115 kV 1
27SP	S2B	1b	111.0% loading on Beatrice-BPS 115 kV 1 FLO Beatrice-BPS 115 kV 2
27SP	S2B	1c	114.7% loading on Firth-Olive Creek 115 kV FLO S1263 Wbrock 161/69 kV Trf
27SP	S2B	1c	<b>101.6% loading on Beatrice-Harbine 115 kV SYSTEM INTACT</b>
27SP	S2B	1c	115.5% loading on Beatrice-Harbine 115 kV FLO Daykin - Elm Creek 345 kV
27SP	S2B	1c	111.5% loading on Beatrice-BPS 115 kV 2 FLO Beatrice-BPS 115 kV 1
27SP	S2B	1c	111.0% loading on Beatrice-BPS 115 kV 1 FLO Beatrice-BPS 115 kV 2
27SP	S2B	1d	110.8% loading on Firth-Olive Creek 115 kV FLO S1263 Wbrock 161/69 kV Trf
27SP	S2B	1d	<b>101.7% loading on Beatrice-Harbine 115 kV SYSTEM INTACT</b>
27SP	S2B	1d	115.6% loading on Beatrice-Harbine 115 kV FLO Daykin - Elm Creek 345 kV
27SP	S2B	1d	102.3% loading on Beatrice-BPS 115 kV 2 FLO Beatrice-BPS 115 kV 1
27SP	S2B	1d	101.7% loading on Beatrice-BPS 115 kV 1 FLO Beatrice-BPS 115 kV 2
27SP	S2B	1e	111.2% loading on Firth-Olive Creek 115 kV FLO S1263 Wbrock 161/69 kV Trf
27SP	S2B	1e	<b>101.8% loading on Beatrice-Harbine 115 kV SYSTEM INTACT</b>
27SP	S2B	1e	115.6% loading on Beatrice-Harbine 115 kV FLO Daykin - Elm Creek 345 kV
27SP	S2B	1e	102.3% loading on Beatrice-BPS 115 kV 2 FLO Beatrice-BPS 115 kV 1

Case	Dispatch Scenario	Transmission Option	Thermal Issue
27SP	S2B	1e	101.8% loading on Beatrice-BPS 115 kV 1 FLO Beatrice-BPS 115 kV 2
27SP	S2C	1a	104.4% loading on Firth-Olive Creek 115 kV FLO S1263 Wbrock 161/69 kV Trf
27SP	S2C	1b	104.4% loading on Firth-Olive Creek 115 kV FLO S1263 Wbrock 161/69 kV Trf
27SP	S2C	1c	104.2% loading on Firth-Olive Creek 115 kV FLO S1263 Wbrock 161/69 kV Trf
27SP	S2C	1d	104.6% loading on Firth-Olive Creek 115 kV FLO S1263 Wbrock 161/69 kV Trf
27SP	S2C	1e	103.6% loading on Firth-Olive Creek 115 kV FLO S1263 Wbrock 161/69 kV Trf
27SP	S2D	1a	None
27SP	S2D	1b	None
27SP	S2D	1c	None
27SP	S2D	1d	None
27SP	S2D	1e	None
27SP	S2E	1a	None
27SP	S2E	1b	None
27SP	S2E	1c	None
27SP	S2E	1d	None
27SP	S2E	1e	None

**Table 3. 2027 Winter Peak Loadflow Study Result Summary**

Case	Dispatch Scenario	Transmission Option	Thermal Issue
27WP	S00	1a	None
27WP	S00	1b	None
27WP	S00	1c	None
27WP	S00	1d	None
27WP	S00	1e	None
27WP	S2A	1a	99.2% loading on Beatrice-Harbine 115 kV FLO Daykin - Elm Creek 345 kV
27WP	S2A	1a	104.7% loading on Firth-Olive Creek 115 kV FLO S1263 Wbrock 161/69 kV Trf
27WP	S2A	1b	99.2% loading on Beatrice-Harbine 115 kV FLO Daykin - Elm Creek 345 kV
27WP	S2A	1b	104.7% loading on Firth-Olive Creek 115 kV FLO S1263 Wbrock 161/69 kV Trf
27WP	S2A	1c	99.0% loading on Beatrice-Harbine 115 kV FLO Daykin - Elm Creek 345 kV
27WP	S2A	1c	104.2% loading on Firth-Olive Creek 115 kV FLO S1263 Wbrock 161/69 kV Trf
27WP	S2A	1d	99.2% loading on Beatrice-Harbine 115 kV FLO Daykin - Elm Creek 345 kV
27WP	S2A	1d	104.4% loading on Firth-Olive Creek 115 kV FLO S1263 Wbrock 161/69 kV Trf
27WP	S2A	1e	98.9% loading on Beatrice-Harbine 115 kV FLO Daykin - Elm Creek 345 kV
27WP	S2A	1e	104.3% loading on Firth-Olive Creek 115 kV FLO S1263 Wbrock 161/69 kV Trf
27WP	S2B	1a	109.7% loading on Firth-Olive Creek 115 kV FLO S1263 Wbrock 161/69 kV Trf
27WP	S2B	1a	105.0% loading on Beatrice-Harbine 115 kV FLO Daykin - Elm Creek 345 kV
27WP	S2B	1a	101.0% loading on Beatrice-BPS 115 kV 2 FLO Beatrice-BPS 115 kV 1
27WP	S2B	1a	100.5% loading on Beatrice-BPS 115 kV 1 FLO Beatrice-BPS 115 kV 2
27WP	S2B	1b	109.7% loading on Firth-Olive Creek 115 kV FLO S1263 Wbrock 161/69 kV Trf
27WP	S2B	1b	105.0% loading on Beatrice-Harbine 115 kV FLO Daykin - Elm Creek 345 kV
27WP	S2B	1b	101.0% loading on Beatrice-BPS 115 kV 2 FLO Beatrice-BPS 115 kV 1
27WP	S2B	1b	100.5% loading on Beatrice-BPS 115 kV 1 FLO Beatrice-BPS 115 kV 2
27WP	S2B	1c	109.6% loading on Firth-Olive Creek 115 kV FLO S1263 Wbrock 161/69 kV Trf
27WP	S2B	1c	105.1% loading on Beatrice-Harbine 115 kV FLO Daykin - Elm Creek 345 kV
27WP	S2B	1c	101.0% loading on Beatrice-BPS 115 kV 2 FLO Beatrice-BPS 115 kV 1
27WP	S2B	1c	100.5% loading on Beatrice-BPS 115 kV 1 FLO Beatrice-BPS 115 kV 2
27WP	S2B	1d	109.9% loading on Firth-Olive Creek 115 kV FLO S1263 Wbrock 161/69 kV Trf
27WP	S2B	1d	105.2% loading on Beatrice-Harbine 115 kV FLO Daykin - Elm Creek 345 kV
27WP	S2B	1d	101.1% loading on Beatrice-BPS 115 kV 2 FLO Beatrice-BPS 115 kV 1
27WP	S2B	1d	100.6% loading on Beatrice-BPS 115 kV 1 FLO Beatrice-BPS 115 kV 2
27WP	S2B	1e	110.4% loading on Firth-Olive Creek 115 kV FLO S1263 Wbrock 161/69 kV Trf
27WP	S2B	1e	105.2% loading on Beatrice-Harbine 115 kV FLO Daykin - Elm Creek 345 kV
27WP	S2B	1e	115.6% loading on Beatrice-Harbine 115 kV FLO Daykin - Elm Creek 345 kV
27WP	S2B	1e	101.2% loading on Beatrice-BPS 115 kV 2 FLO Beatrice-BPS 115 kV 1
27WP	S2B	1e	100.7% loading on Beatrice-BPS 115 kV 1 FLO Beatrice-BPS 115 kV 2
27WP	S2C	1a	102.7% loading on Firth-Olive Creek 115 kV FLO S1263 Wbrock 161/69 kV Trf
27WP	S2C	1b	102.7% loading on Firth-Olive Creek 115 kV FLO S1263 Wbrock 161/69 kV Trf
27WP	S2C	1c	102.4% loading on Firth-Olive Creek 115 kV FLO S1263 Wbrock 161/69 kV Trf

Case	Dispatch Scenario	Transmission Option	Thermal Issue
27WP	S2C	1d	102.3% loading on Firth-Olive Creek 115 kV FLO S1263 Wbrock 161/69 kV Trf
27WP	S2C	1e	101.8% loading on Firth-Olive Creek 115 kV FLO S1263 Wbrock 161/69 kV Trf
27WP	S2D	1a	None
27WP	S2D	1b	None
27WP	S2D	1c	None
27WP	S2D	1d	None
27WP	S2D	1e	None
27WP	S2E	1a	None
27WP	S2E	1b	None
27WP	S2E	1c	None
27WP	S2E	1d	None
27WP	S2E	1e	None

### *Loadflow Study Result Summary*

The loadflow study results show the transmission option 1e does not have materially different or adverse reliability performance than either of the other transmission options evaluated in this analysis. There were no additional transmission constraint issues associated with transmission option 1e. Transmission option 1e is estimated to be the lowest cost alternative of the transmission options evaluated in this analysis. The results demonstrate the transmission constraints discovered in this study are related to the alternative generation dispatch / load scenarios and not the transmission options under consideration. Based on these study results, transmission option 1e is the preferred transmission solution to the short circuit issues identified in the Sheldon/Olive Creek areas.

Also, there were several additional transmission constraints discovered in this analysis due to the dispatch of existing NITS resources and alternative Monolith load scenarios. It is recommended that these constraints be addressed for the GEN-2023-222, GEN-2023-223, GEN-2023-224, and GEN-2023-225 GI requests to connect reliably. There were 4 transmission lines identified that would need to be rebuilt to address the local area transmission constraints in this study:

- Olive Creek – Firth 115 kV (L1180B)
- Beatrice Power Station – Beatrice 115 kV Circuit #1 (L1177A)
- Beatrice Power Station – Beatrice 115 kV Circuit #2 (L1178A)
- Beatrice – Harbine 115 kV (L1175C)

## Interconnection Facility and Network Upgrades

NPPD's Engineering, Asset Management, and Project Management groups have reviewed the interconnection facility upgrades that are required for SPP DISIS-2023-001 Generation Interconnection projects. Detailed cost estimates have been prepared for the facility upgrades that were identified in the system impact study for the requests. The prepared cost estimates are study level estimates (+20%/-20%) and assume implementation of standard NPPD construction and procurement practices. The cost estimates for the interconnection facilities are below:

### Interconnection Facility Upgrades

- Beatrice Power Station 345 kV Substation
  - GEN-2023-222/GEN-2023-223
    - 478 MW Thermal
    - 239 MW Thermal
  - Addition of Beatrice Power Station 345 kV Substation
    - Includes 345/115 kV Transformer (relocated existing Olive Creek T2)
  - 60 Month Lead Time

**\$ 44,400,000**
  
- Princeton Road Station 345 kV Substation (connected to Olive Creek 345 kV Substation)
  - GEN-2023-224/GEN-2023-225
    - 478 MW Thermal
    - 217 MW Thermal
  - Addition of Princeton Road Station 345 kV Substation connected to the existing Olive Creek 345 kV substation and interconnected with existing LES transmission lines at the site.
    - Interconnects LES L1099 & LES L3503
    - Single 345 kV line from Princeton Road Station to Olive Creek
    - Includes 345/115 kV Transformer (relocated existing Moore T1)
    - 115 kV line connection from Princeton Road Station to Sheldon using existing Moore T1 115 kV line & terminal at Sheldon
  - 60 Month Lead Time

**\$ 78,600,000**

## Network Upgrades

- Build Daykin 345 kV Substation
  - Upgrade would require new 345 kV substation interconnected to the planned Tobias – Elm Creek 345 kV line approximately 10 miles south of the existing Tobias 345 kV substation assumed to be near Daykin, NE.
  - At least 1793 MVA
  - 60 Month Lead Time

**\$ 26,800,000**
  
- Build a new Beatrice Power Station – Olive Creek 345 kV line
  - Upgrade would require a new 345 kV transmission line from the new Beatrice Power Station 345 kV substation to Olive Creek 345 kV including terminal upgrades at both ends.
  - At least 1793 MVA
  - 60 Month Lead Time

**\$ 76,500,000**
  
- Build a new Beatrice Power Station – Daykin 345 kV line
  - Upgrade would require a new 345 kV transmission line from the new Beatrice Power Station 345 kV substation to the proposed new Daykin 345 kV substation (interconnected to the planned Tobias – Elm Creek 345 kV line) including terminal upgrades at both ends.
  - At least 1793 MVA
  - 60 Month Lead Time

**\$ 56,300,000**
  
- Lowell – Minden 115 kV Line Upgrade
  - Upgrade existing Lowell – Minden 115 kV Line to the conductor rating at 100 Deg C and terminal upgrades at both ends.
  - At least 175 MVA (summer)
  - 36 Month Lead Time

**\$ 1,000,000**
  
- Beatrice 115 kV Substation – Breaker Upgrades
  - Upgrade existing 115 kV breakers in Beatrice 115 kV Substation to accommodate short circuit impacts identified in the Facility Study.
  - 36 Month Lead Time

**\$ 1,800,000**

Network Upgrades allocated to GI requests external to NPPD

- Build second Red Willow 345/115 kV transformer
    - Upgrade would require expansion of the Red Willow 345 kV substation to accommodate a second 345 / 115 kV transformer at this location. Upgrade would include terminal upgrades at both voltage levels and the addition of a second 345 / 115 kV transformer. Upgrade Bay 104/106 due to short circuit study results.
    - At least 336 MVA
    - 60 Month Lead Time
- \$ 35,400,000**

Additional Network Upgrades identified in NPPD Loadflow Study

- Uprate Olive Creek – Firth 115 kV line
    - Upgrade would require conductor uprates and terminal upgrades at both ends of L1180B.
    - At least 137 MVA
    - 60 Month Lead Time
- \$ 2,000,000**
- Uprate Beatrice Power Station – Beatrice 115 kV line #1
    - Upgrade would require conductor uprates and terminal upgrades at both ends of L1177A.
    - At least 250 MVA
    - 60 Month Lead Time
- \$ 5,200,000**
- Uprate Beatrice Power Station – Beatrice 115 kV line #2
    - Upgrade would require conductor uprates and terminal upgrades at both ends of L1178A.
    - At least 250 MVA
    - 60 Month Lead Time
- \$ 4,700,000**
- Uprate Beatrice – Harbine 115 kV line
    - Upgrade would require conductor uprates and terminal upgrades at both ends of L1175C.
    - At least 250 MVA
    - 60 Month Lead Time
- \$ 11,200,000**

Preliminary one-line diagrams for the local area and each generation interconnection project are in Appendix 2.

Interconnection Facilities and Network Upgrade project schedule details will be further discussed in the development of the generator interconnection agreements (GIA) and the milestones associated with the generation interconnection projects.

### **Contingent Upgrades**

The results of DISIS-2023-001 documented that several Generation Interconnection requests are contingent on the completion of the following previously allocated required network upgrades:

- Tobias – Elm Creek 345 kV transmission line (ITP24)

If the generation interconnection projects proceed to the generation interconnection agreement, then an operating study may need to be performed to fully assess and evaluate the operation of the generation facility and network upgrades in accordance with NERC Standards. The operating study requirement will be included in the generation interconnection agreement with NPPD. If any generation interconnection projects are identified to have significant impact on the GGS Stability Interface (Flowgate #6006) and LRS/DC stability limitations in western NE, then the operating study will need to take these issues into account. The operating study may also need to evaluate the reactive power control requirements and associated equipment necessary to meet operational voltage requirements at the requested point of interconnection.

## **Short Circuit Study - Final**

NPPD's Engineering group has reviewed the short circuit impacts of the SPP DISIS-2023-001 Generation Interconnection projects and updated list of network upgrades interconnected to the NPPD transmission system. The result of this study is documented in Appendix 1. The short circuit study identified several breakers that required mitigation. The details of these mitigations are listed below. These mitigation projects should be included in the appropriate Generation Interconnection agreements associated with the DISIS-2023-001 GI projects.

- The Olive Creek and Sheldon 115 kV breaker issues will be mitigated by implementing transmission option 1e below.

### Transmission Option 1e

- Relocate Moore T1 transformer to Princeton Road Station and install new 115 kV line from Princeton Road to Sheldon using the existing Moore T1 115 kV tie line terminal at Sheldon Station.
  - Relocate Olive Creek T2 transformer to Beatrice Power Station.
  - Single 345 kV transmission line from Princeton Road Station to Olive Creek.
  - Install additional grounding on generation interconnection request step-up transformers associated with all IBR's at Olive Creek 115 kV substation (GEN-2013-002, GEN-2013-019, GEN-2019-041, GEN-2021-027)
- The Beatrice 115 kV Bay 1110/1112/1120/1122 breakers will be mitigated through replacement with higher capacity units.
  - The Red Willow 345 kV Bay 104/106 breakers will be mitigated through the 2<sup>nd</sup> Red Willow 345/115 kV transformer project.



## **Appendix 1**

### **NPPD Short Circuit Study Report DISIS-2023-001 Initial & Final Plans**



# Short Circuit Study

## Model Development

### Computer Programs

The Aspen OneLiner software program was utilized to perform short circuit simulations and studies on the transmission system. Where elements were added to the short-circuit model, best estimates for impedance parameters were used based on available data and typical modeling practices. Short-circuit calculation options used were as follows:

- Flat voltage profile with  $V(\text{pu}) = 1.0$
- Generator Impedance = Subtransient
- Ignore loads, transmission line  $G+jB$ , and shunts with positive sequence values

OneLiner was used to calculate three-phase (3PH) and single-line-to-ground (SLG) system-intact bus fault currents for all system buses associated with interrupting devices being evaluated in this study. For devices that the full bus fault current approached or exceeded the device's interrupting rating, more detailed fault calculations were done, calculating the maximum phase current through the breaker for close-in faults, close-in faults with the remote end open, and bus faults with all other branches to the bus open. The maximum phase current of these faults was recorded.

### Base System Model Additions (“Base Case”)

The base system model used by the transmission system protection department as of October 27, 2025 was used as the starting point for the short-circuit model used for this study. The base system model included all projects that were in-service at the time the model was copied. All Nebraska-area generation in the short-circuit model was enabled in order to provide maximum short-circuit current. For the study base case, planned system upgrades in the area of the studied projects and prior-queued large generator interconnections expected to be in-service prior to the projects being studied were added to the base case model. The following table lists the prior-queued large generator interconnections that were added to the base model for this study.

**Prior Queued Large Generator Interconnections**

<b>Queue Designation</b>	<b>Proposed POI</b>	<b>Capacity (MW)</b>
GEN-2013-002	Hallam 115kV / Panama IBR to Olive Creek	50.6
GEN-2013-019	Hallam 115kV / Panama IBR to Olive Creek	73.6
GEN-2016-074	Sweetwater 345kV (Expand substation)	200
GEN-2017-144	Holt County 345kV Substation (Expand substation)	200
GEN-2017-181	Tobias 345kV Substation (Expand substation)	300
GEN-2017-182	Tobias 345kV Substation (Expand substation)	128
GEN-2017-201	Turtle Creek 345kV connect at Sholes WF	250
GEN-2017-234	Greeley 115kV Substation (New substation)	115
GEN-2018-060	Macon 345kV (Expand substation)	50
GEN-2018-125	Etna 345kV (New substation)	231
GEN-2018-131	Pierce County 345kV (New substation)	221.4
GEN-2018-132	Pierce County 345kV (New substation)	201.6
GEN-2019-039	Butler County 115kV (New substation)	174.5
GEN-2019-041	Olive Creek 115kV (Expand substation)	78
GEN-2020-011	Axtell 345kV Substation (Expand substation)	320
GEN-2020-013	Orleans 115kV Substation (Expand substation)	215
GEN-2020-069	Kilgore 115kV Substation (New substation)	52.85
GEN-2021-027	Olive Creek 115kV Substation (Expand substation)	102
GEN-2021-057	Antelope 345kV Substation (Expand substation)	300

In addition to the prior-queued large generator interconnections, planned system upgrades in the area of the studied projects were added to the base model. These include:

- The planned 345kV line from GGS – Thedford – Holt County “RPLAN” was included with a 345kV/115kV tie transformer at Thedford 115 kV
- New 345kV line from Antelope to Holt County
- New Olive Creek sub addition near Mark Moore/Sheldon
- Upgrade of the Columbus East T3 to 336MVA
- Stanton North expansion for a new 100MVA load-serving transformer, future 115kV line Stanton North to Norfolk, Hoskins T1 replaced with a 336MVA
- Upgrade of Mark Moore T1 replacement with a 417MVA
- Rebuild of L1153B Columbus SE to new collector sub for G19-39-TAP (Butler County) to Rising City
- Rebuild of L1132 Holdrege-Orleans to new collector sub for G20-13 at/near Orleans
- Addition at Antelope of a 345kV/115kV transformer at 417MVA
- Addition at Axtell of a 345kV/115kV transformer at 417MVA
- Rebuild of L1067 Axtell-Kearney.

## Model Additions for Projects Being Studied (“Study Case”)

The base-case study model was modified to include the new generation interconnections being considered in this study as well as the system upgrades identified to accommodate this additional generation. The following table lists the large generator interconnections that were added to the study-case model for this study.

**Large Generator Interconnections Added to Study Case**

<b>Queue Designation</b>	<b>Proposed POI</b>	<b>Capacity (MW)</b>
GEN-2023-199	Twin Church 230kV Substation (Expand substation)	250
GEN-2023-222	NPPD BPS 345kV Substation (New substation)	478
GEN-2023-223	NPPD BPS 345kV Substation (New substation)	239
GEN-2023-224	NPPD Princeton Road 345kV Substation (New substation)	478
GEN-2023-225	NPPD Princeton Road 345kV Substation (New substation-115kV)	217

In addition to the DISIS-2021-001 generator interconnections, network system upgrades in the area of the studied projects were added to the base model. These include:

- New 345kV line Tobias 345kV substation to Elm Creek Kansas
- New substation Daykin 345kV ~10mi from Tobias on Tobias-ElmCreek
- New 345kV line BPS 345kV substation to Olive Creek
- New 345kV line Olive Creek 345kV substation to Princeton Road
- Addition at Red Willow of a 345kV/115kV transformer at 336MVA
- Rebuild of L1089 115kV Lowell to Minden

The short circuit study revealed extremely high fault currents on several 115kV buses. An additional short circuit was performed using some system modifications to limit the 115kV fault current to below 63kA. Mitigation changes to include:

- Move Mark Moore 345kV/115kV transformer at 417MVA to use at Princeton Road
- Move Olive Creek 345kV/115kV transformer #2 at 417MVA to use at BPS 345kV
- Existing L1180B Olive Creek-Firth rebuild to 137MVA
- Existing L1177A Beatrice-BPS 115kV rebuild to 250MVA
- Existing L1178A Beatrice-BPS 115kV rebuild to 250MVA
- Existing L1175C Beatrice-Harbine rebuild to 250MVA

## Study Methodology

Circuit breaker, circuit switcher, and fuse ratings were identified by querying NPPD's SAP equipment database and extracting equipment data including short-circuit ratings. Breaker ratings given on an asymmetrical (total current) basis were converted to symmetrical current ratings using an assumed maximum system operating voltage of 1.00 per unit.

The calculated short-circuit current at the equipment bus was extracted from the short-circuit results from Aspen OneLiner and compared against the interrupting device interrupting rating. It is recommended that all equipment be replaced if it is found to be at or above 95% of its interrupting rating and seeing an increase of 1% or more in its interrupting duty as a result of the studied projects.

## Results

The following devices were found to be above 95% of their interrupting rating due to the addition of the projects considered in this study and are recommended for mitigation.

Location – Breaker	Manuf.	Model Number	Interrupting Rating	Max Expected Interrupting (A)	Relative Change (%)	Max Current (% of Rating)
All (21) OLIVE CREEK 115kV breakers	GENERAL ELECTRIC	Dt1-145-63-f1	63000	67096	19.5%	106.5%
All (15) SHELDON 115kV GE breakers	GENERAL ELECTRIC	DT1-145-63-F1	63000	66233	24.0%	105.1%
SHELDON 115-BAY 1126	SIEMENS	SPS2S-123-63-2	63000	69545	24.0%	110.4%
RED WILLOW 345-BAY 104	ABB	RMAG	25000	23741	7.1%	95.0%
RED WILLOW 345-BAY 106	ABB	RMAG	25000	23741	7.1%	95.0%

The mitigation changes studied would change the affected breakers to the list below:

<b>Location – Breaker</b>	<b>Manuf.</b>	<b>Model Number</b>	<b>Interrupting Rating</b>	<b>Max Expected Interrupting (A)</b>	<b>Relative Change (%)</b>	<b>Max Current (% of Rating)</b>
BEATRICE 115-BAY 1110	ALLIS CHALMERS	BZO-121-20- 7	20000	19356.4	46.6%	96.8%
BEATRICE 115-BAY 1112	ALLIS CHALMERS	BZO-121-20- 7	20000	19356.4	46.6%	96.8%
BEATRICE 115-BAY 1120	MCGRAW EDISON	AHF-48-121- 20	20000	19356.4	46.6%	96.8%
BEATRICE 115-BAY 1122	MCGRAW EDISON	AHF-48-121- 20	20000	19356.4	46.6%	96.8%
RED WILLOW 345-BAY 104	ABB	RMAG	25000	23741	7.1%	95.0%
RED WILLOW 345-BAY 106	ABB	RMAG	25000	23741	7.1%	95.0%

## Mitigation Summary

The Olive Creek and Sheldon 115 kV breaker issues will be mitigated by implementing transmission option 1e below.

### Transmission Option 1e

- Relocate Moore T1 transformer to Princeton Road Station and install new 115 kV line from Princeton Road to Sheldon using the existing Moore T1 115 kV tie line terminal at Sheldon Station.
- Relocate Olive Creek T2 transformer to Beatrice Power Station.
- Single 345 kV transmission line from Princeton Road Station to Olive Creek.
- Install additional grounding on generation interconnection request step-up transformers associated with all IBR's at Olive Creek 115 kV substation (GEN-2013-002, GEN-2013-019, GEN-2019-041, GEN-2021-027)

The Beatrice 115 kV Bay 1110/1112/1120/1122 breakers will be mitigated through replacement with higher capacity units.

The Red Willow 345 kV Bay 104/106 breakers will be mitigated through the 2<sup>nd</sup> Red Willow 345/115 kV transformer project.

After the mitigations, all devices were found to be below 95% of the interrupting ratings after the addition of the projects considered in this study.

## **Appendix 2**

### **PRS & BPS Local Area One-Line Diagrams**

Transmission Topology 1e included as part of interconnection plan for PRS/BPS generation additions.



# DISIS-2023-001 Interconnection & Network Upgrades

## Transmission Topology 1a

SPP re-study1 with LES interconnections added

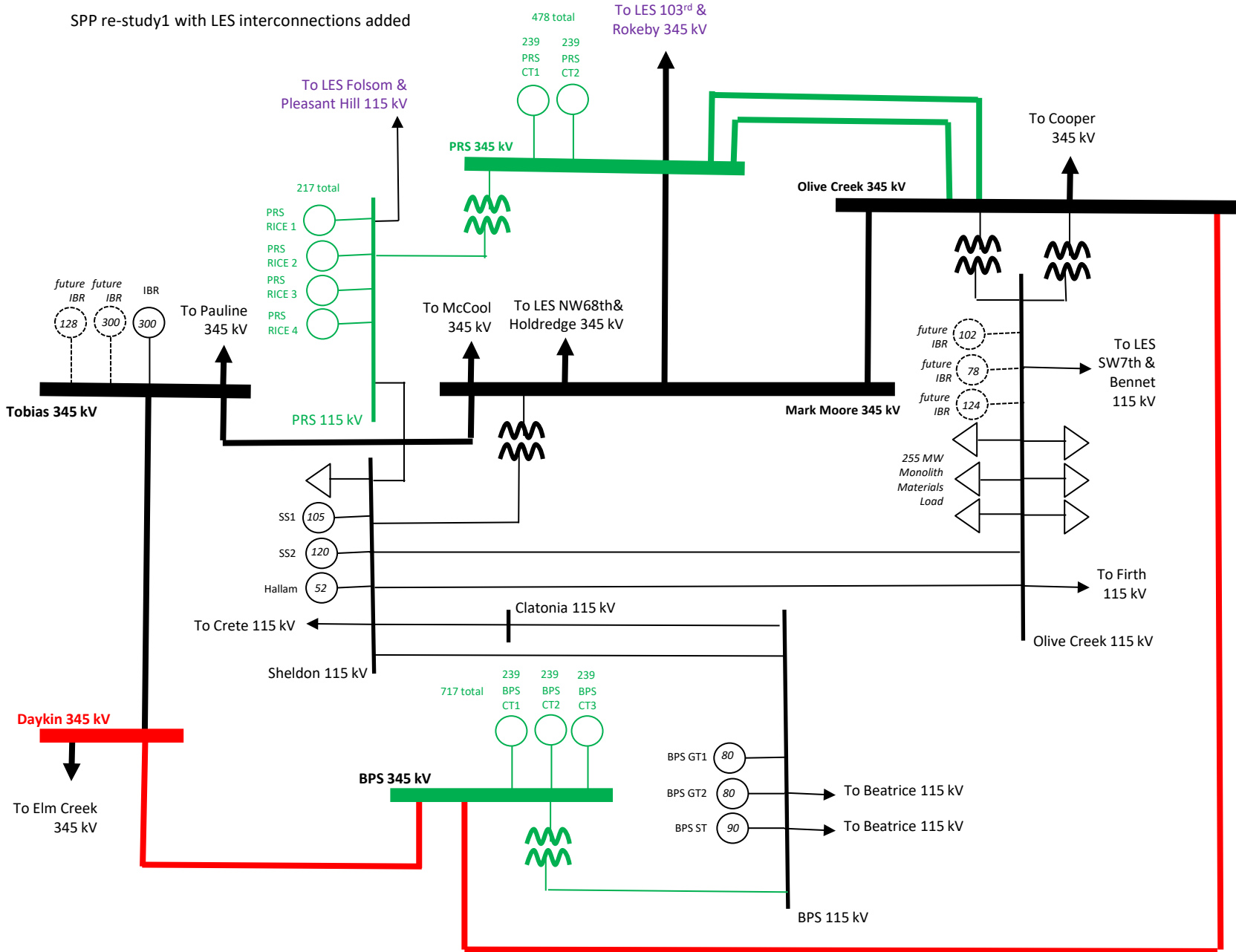

# DISIS-2023-001 Interconnection & Network Upgrades

## Transmission Topology 1b

1a + remove 1 PRS-Olive Creek 345 kV line

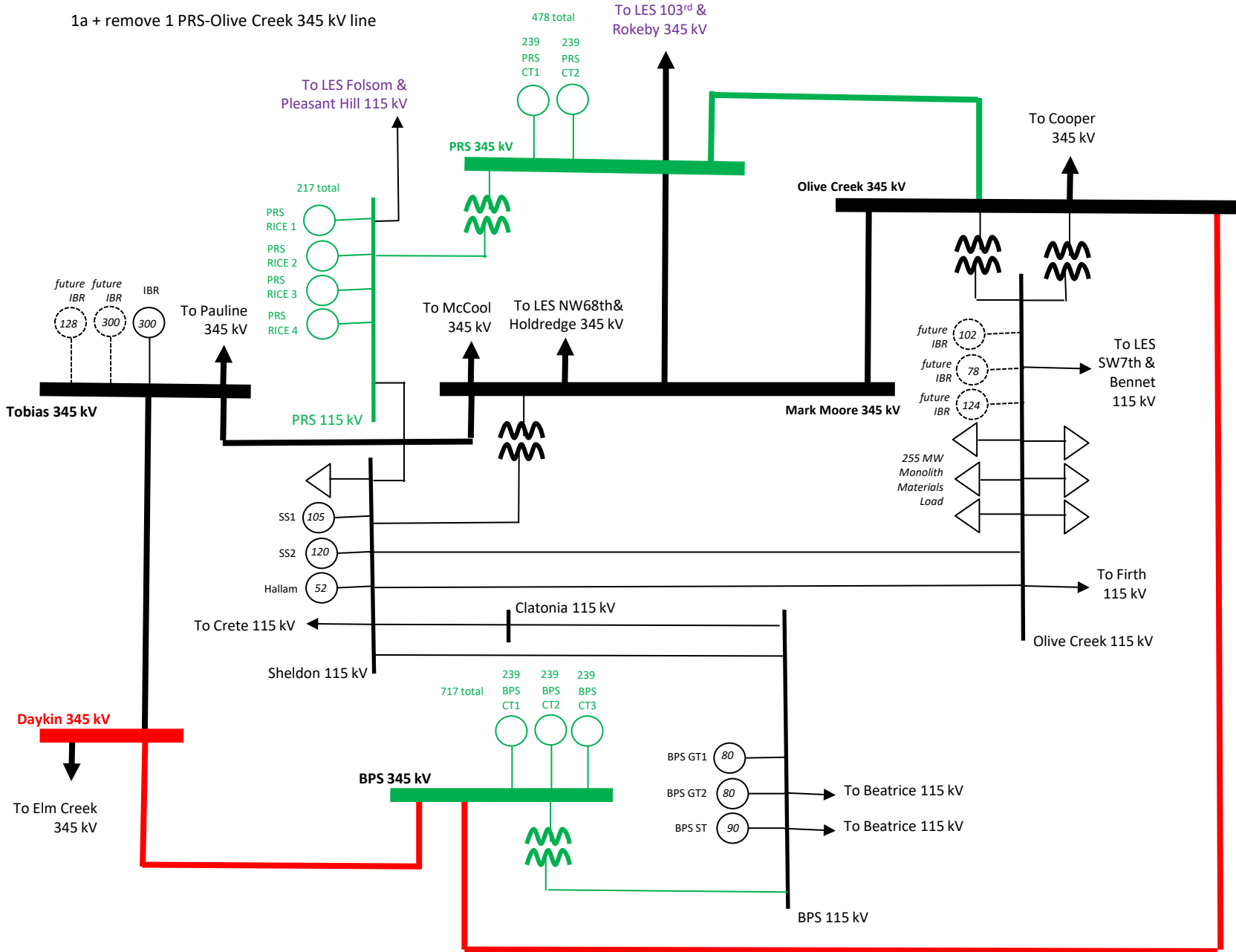

# DISIS-2023-001 Interconnection & Network Upgrades

## Transmission Topology 1c

1b + remove 1 Olive Creek 345/115 kV transformer

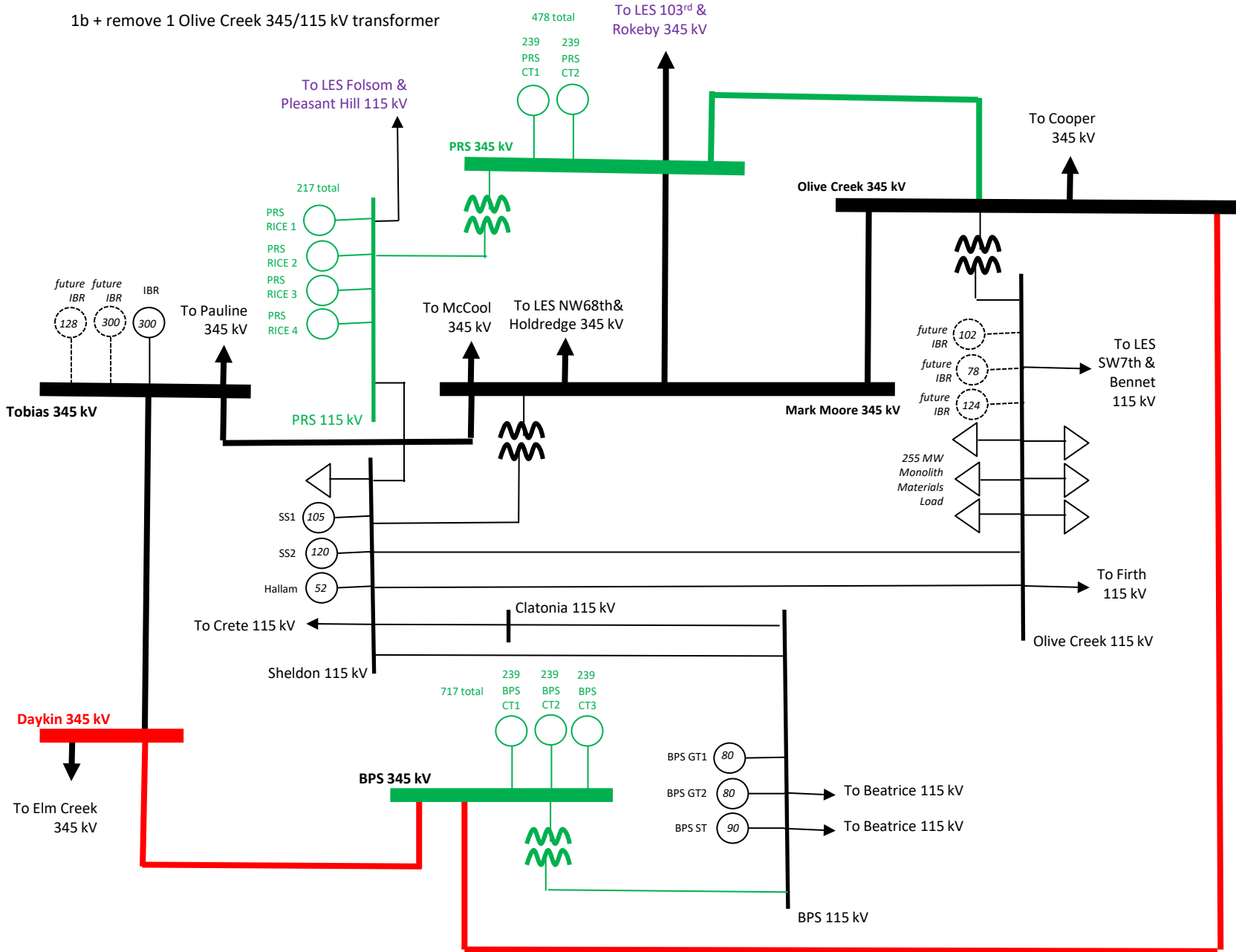

# DISIS-2023-001 Interconnection & Network Upgrades

## Transmission Topology 1d

1b + remove Moore 345/115 kV transformer + add 2<sup>nd</sup> PRS-  
Sheldon 115 kV circuit

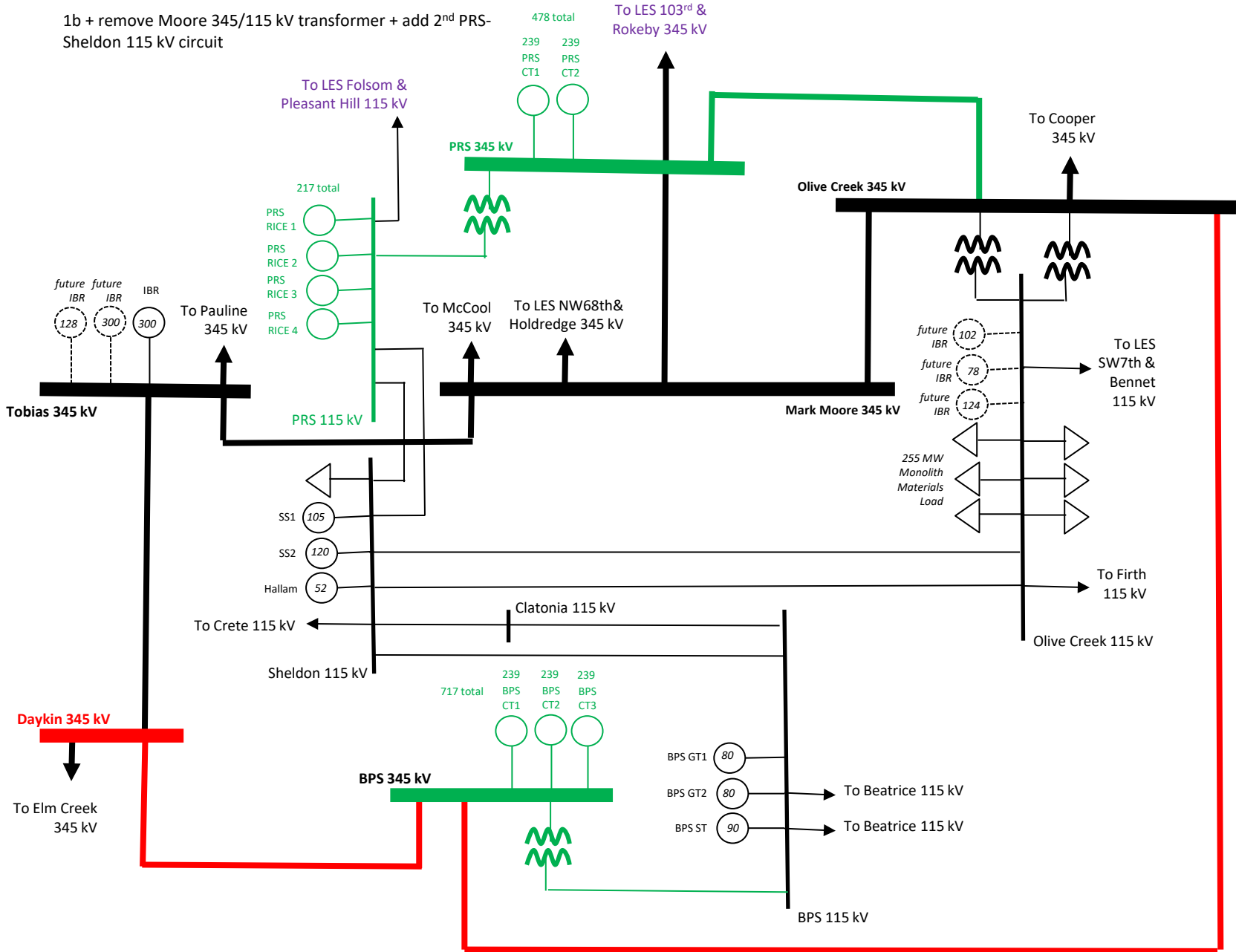

# DISIS-2023-001 Interconnection & Network Upgrades

## Transmission Topology 1e

1b + remove Moore 345/115 kV transformer + add 2<sup>nd</sup> PRS-  
Sheldon 115 kV circuit + remove Olive Creek 345/115 kV T2

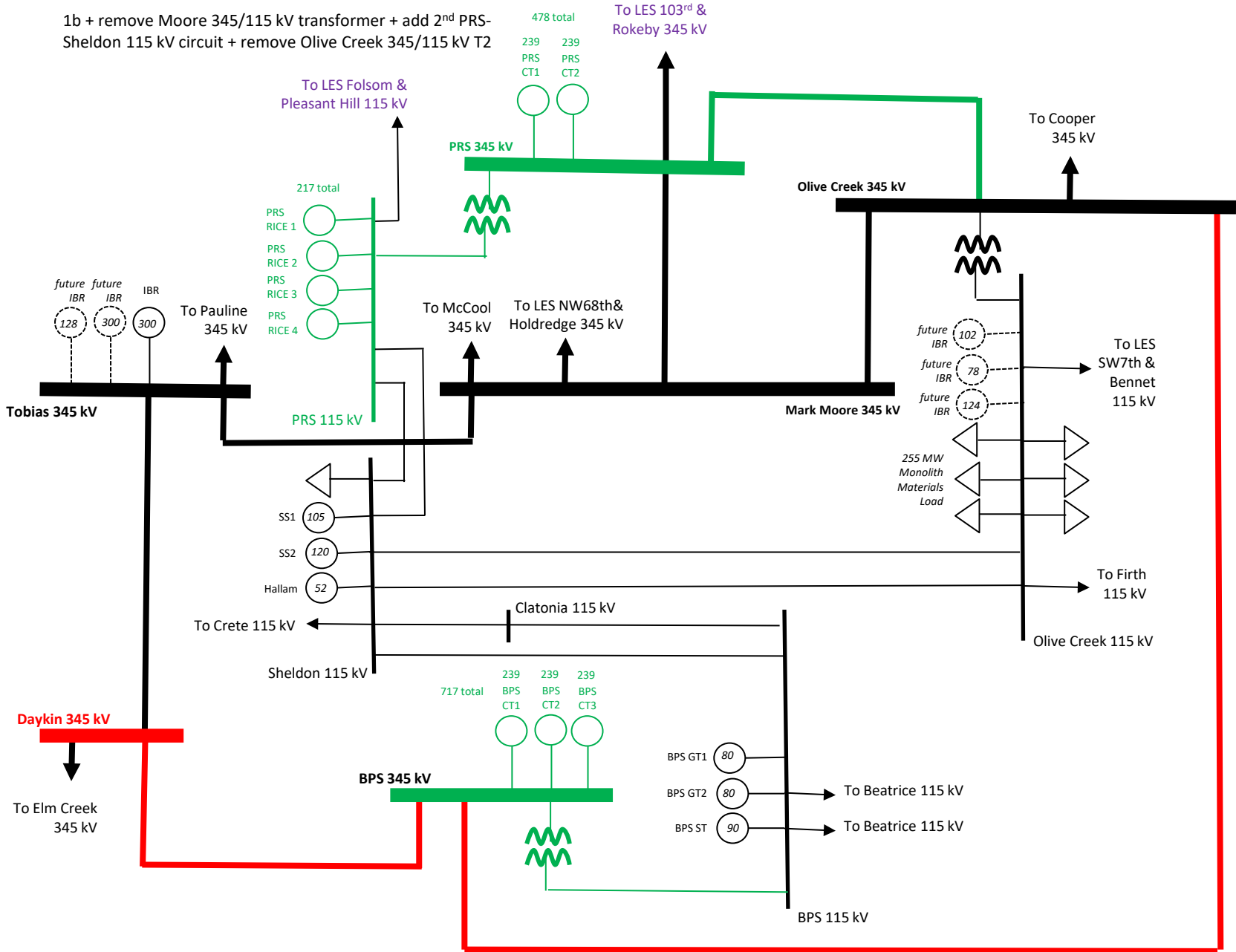



## **Appendix 3**

### **Generation Interconnection Facilities One-Line Diagrams**



# Beatrice Power Station 345/115 kV

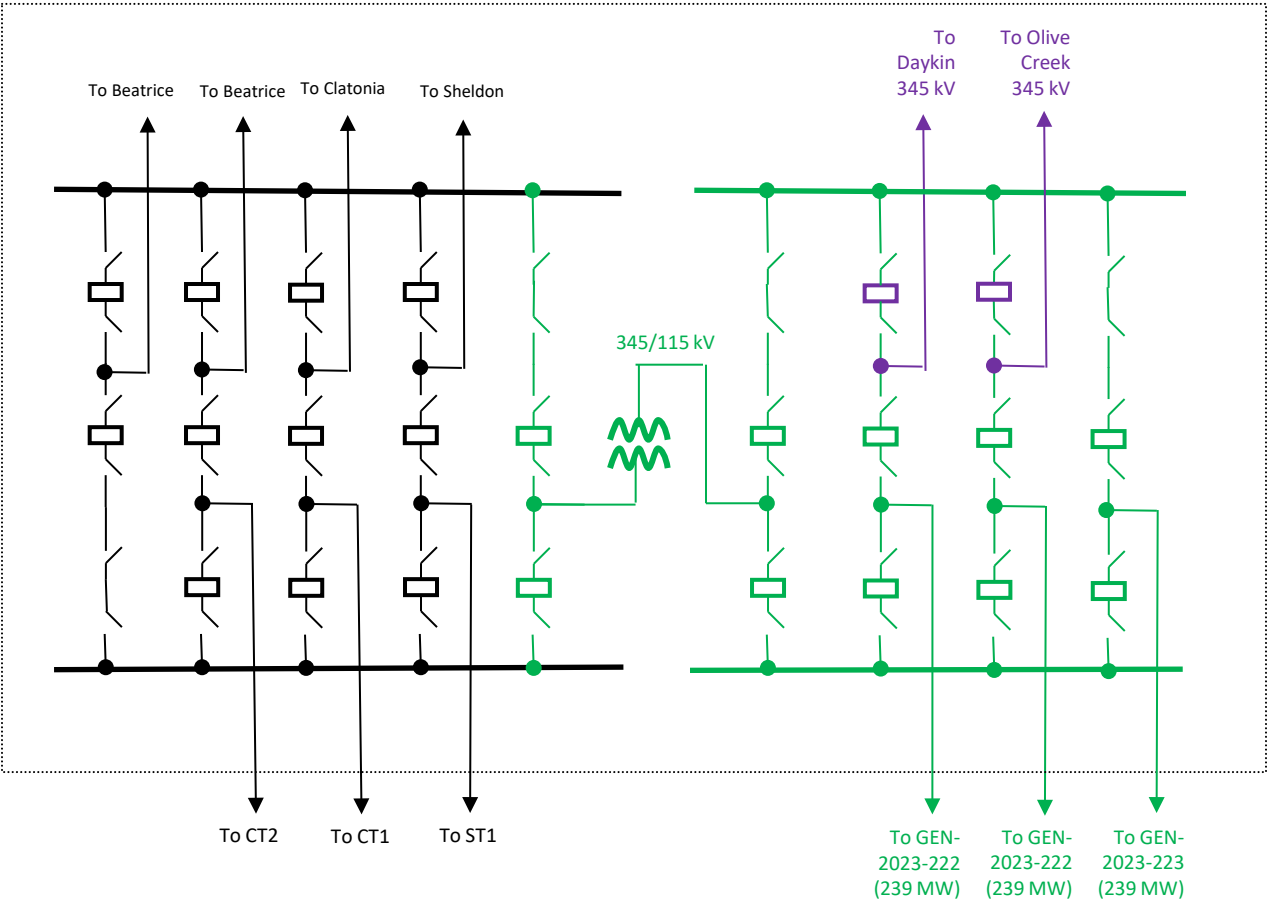

- DISIS-2023-001 Interconnection Facilities for GEN-2023-222 and GEN-2023-223
- Network Upgrades to address transmission system constraints

# Princeton Road 345/115 kV

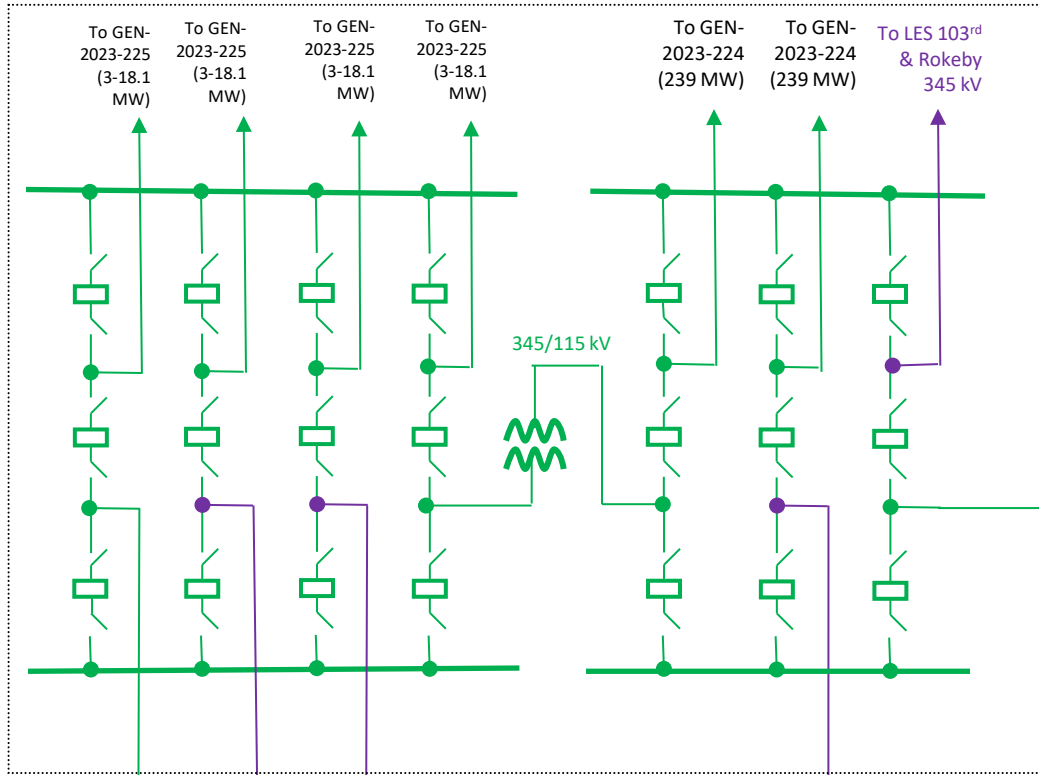

## Olive Creek 345 kV

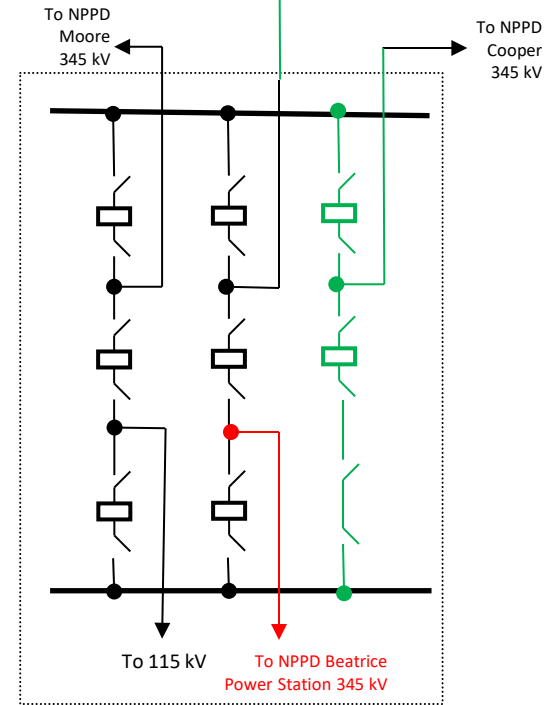

- DISIS-2023-001 Network Upgrades
- DISIS-2023-001 Interconnection Facilities for GEN-2023-224 and GEN-2023-225
- LES Transmission Line Conflicts resolved through interconnection with new Princeton Road 345/115 kV substation



## **Facilities Study For Southwest Power Pool (SPP)**

Group 5  
DISIS-2023-Network Upgrades

Xcel Energy Services, Inc.  
Southwestern Public Service Co.  
Transmission Planning South  
Updated 3/12/2026

# Executive Summary

The Southwest Power Pool (SPP or Transmission Provider [TP]) requested a Facility Study for certain Network Upgrades that were identified in the DISIS-2023-001 Phase 2 Restudy. The results were posted in December 2025.

This report is for the identified Network Upgrade – “Switch Out Carpenter Line Reactor.”

SPP assigned UID 171463 to this project.

It is anticipated that the entire process of this project will require approximately 36 - 42 months to complete after an agreement is signed and an authorization to proceed is received. The estimated costs for the work needed for this project are shown below in Table 1.

**Table 1: Cost Summary<sup>1</sup>**

Switch Out Carpenter Line Reactor to Finney UID 171463	<b>\$ 2,739,899</b>
Switch Out Carpenter Line Reactor to Hitchland UID 171463	<b>\$ 2,002,275</b>
Total:	<b>\$ 4,742,174</b>

---

<sup>1</sup> The cost estimates are 2026 dollars with an accuracy level of ±20%.

# General Description of SPS<sup>2</sup> Facilities

1. **SPS Carpenter Substation:** See Appendix A, Figure A-1 for general vicinity location map of the SPS facility.
2. **Estimated Construction Costs and Schedule**
  - a. **Schedule:** An engineering and construction schedule for this project is estimated at approximately 36 - 42 months. Other factors associated with clearances, equipment delays, and work schedules could cause additional delays. This is applicable after all required agreements are signed and internal approvals are granted.
  - b. All additional costs for work not identified in this study are the sole responsibility of the IC unless other arrangements are made.

---

<sup>2</sup> All modifications to SPS facilities will be owned, maintained, and operated by SPS.

# Appendix A

Figure A-1: General vicinity location map of the Carpenter Substation



SPS 345 kV transmission lines are shown in red.

– END OF REPORT –



## **Facilities Study For Southwest Power Pool (SPP)**

Group 5  
DISIS-2023-Network Upgrades

Xcel Energy Services, Inc.  
Southwestern Public Service Co.  
Transmission Planning South  
Updated 3/12/2026

# Executive Summary

The Southwest Power Pool (SPP or Transmission Provider [TP]) requested a Facility Study for certain Network Upgrades that were identified in the DISIS-2023-001 Phase 2 Restudy. The results were posted in December 2025.

This report is for the identified Network Upgrade – “Switch Out Finney Line Reactors.”

SPP assigned UID 171464 to this project.

It is anticipated that the entire process of this project will require approximately 36 - 42 months to complete after an agreement is signed and an authorization to proceed is received. The estimated costs for the work needed for this project are shown below in Table 1.

**Table 1: Cost Summary<sup>1</sup>**

Switch Out Finney Line Reactor to Carpenter UID 171464	<b>\$ 1,788,278</b>
Total:	<b>\$ 1,788,278</b>

<sup>1</sup> The cost estimates are 2026 dollars with an accuracy level of ±20%.

# General Description of SPS<sup>2</sup> Facilities

1. **SPS Finney Substation:** See Appendix A, Figure A-1 for general vicinity location map of the SPS facility.
2. **Estimated Construction Costs and Schedule**
  - a. **Schedule:** An engineering and construction schedule for this project is estimated at approximately 36 - 42 months. Other factors associated with clearances, equipment delays, and work schedules could cause additional delays. This is applicable after all required agreements are signed and internal approvals are granted.
  - b. All additional costs for work not identified in this study are the sole responsibility of the IC unless other arrangements are made.

---

<sup>2</sup> All modifications to SPS facilities will be owned, maintained, and operated by SPS.

# Appendix A

Figure A-1: General vicinity location map of the Finney Substation

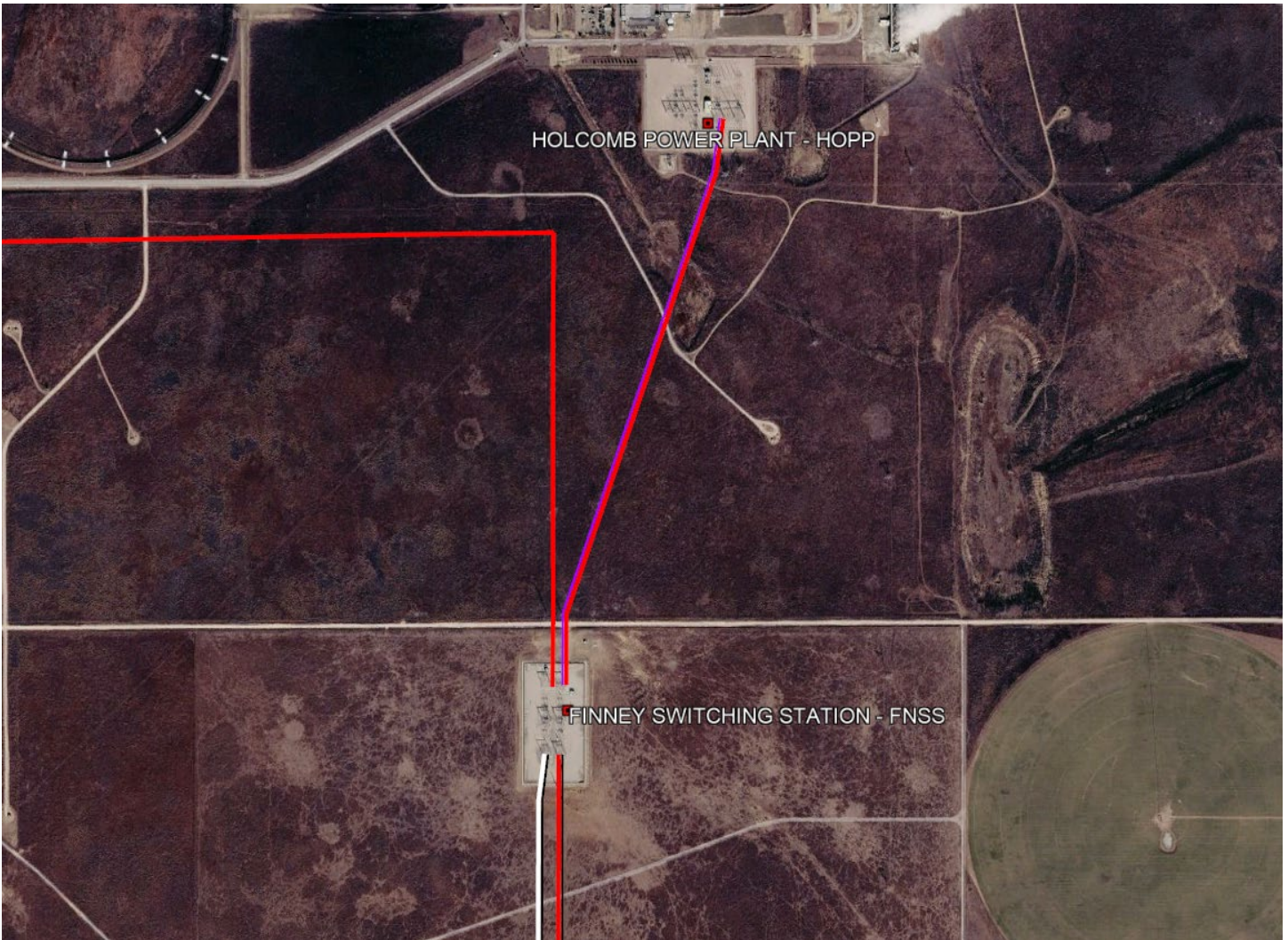

SPS 345 kV transmission lines shown in red, earlier customer's gen-tie line shown in white.

– END OF REPORT –